



晶采光電科技股份有限公司
AMPIRE CO., LTD.

SPECIFICATIONS FOR LCD MODULE

CUSTOMER	
CUSTOMER PART NO.	
AMPIRE PART NO.	AM-640480GTMQW-T00H
APPROVED BY	
DATE	

Approved For Specifications

Approved For Specifications & Sample

AMPIRE CO., LTD.

**TOWER A, 4F, No.114, Sec. 1, HSIN-TAI 5th RD., HIS-CHIH,
TAIPEI HSIEN, TAIWAN(R.O.C.)**

台北縣汐止鎮新台五路一段114號4樓(東方科學園區A棟)

TEL:886-2-26967269, FAX:886-2-26967196 or 886-2-26967270

APPROVED BY	CHECKED BY	ORGANIZED BY

RECORD OF REVISION

Revision Date	Page	Contents	Editor
2006/12/21	-	New Release	Edward
2007/03/22	-	Rename TF640480-02-0 to AM-640480GTMQW-T00H.	Edward
	-	Modify the paragraph arrange.	Edward
	-	Modify the Operation and Storage Temperature.	Edward
	4	Modify Absolute Max. Ratings.	Edward
	4-5	Modify Electrical Characteristics.	Edward
	7-8	Modify Interface Connection.	Edward
	9-10	Modify Input Signal.	Edward
	11	Modify Touch Panel Electrical Specification.	Edward
	12	Modify Optical Characteristics.	Edward
	14	Modify Reliability Test Conditions.	Edward
2007/8/1	4-5	Modify Electrical Characteristics.	Edward
2007/9/6	4-5	Modify Absolute Maximum Ratings	Edward
	5-6	Modify Electrical Characteristics	Edward
	7	Modify Block Diagram	Edward
	8-9	Modify Interface	Edward
	10-11	Modify Input Signal	Edward
	14-15	Modify Optical Characteristics	Edward
	16	Modify Reliability Test Conditions	Edward

1. INTRODUCTION

Ampire Display Module AM640480G is a color active matrix TFT-LCD that uses amorphous silicon TFT as a switching device . This model is composed of a 5.7inch TFT-LCD panel, touch panel, a driving circuit and LED backlight system . This TFT-LCD has a high resolution (640(R.G.B) X 480) and can display up to 262,144 colors .

1-1. Features

- VGA Resolution
- 6 Bits color driver with 1 channel TTL interface
- Wide range operation temperature

1-2. Applications

- Portable TV
- Car PC
- Industrial application
- HMI (Human machine interface)

2. PHYSICAL SPECIFICATIONS

Item	Specifications	unit
Display resolution(dot)	640RGB (W) x 480(H)	dots
Display area	116.16 (W) x 87.12 (H)	mm
Pixel pitch	0.1815 (W) x 0.1815 (H)	mm
Color configuration	R.G.B Vertical stripe	
Overall dimension	127.0(W)x98.43(H)x7.4(D)---(Typ)	mm
Surface treatment	Antiglare , Hard-Coating(3H)	
Brightness	220 nit(typ)	cd/m ²
Contrast ratio	300 : 1	
Backlight unit	LED	
Display color	262,144	colors
Viewing Direction	6 O'CLOCK	
Display Mode	Normally White	

3. ABSOLUTE MAXIMUM RATINGS

ITEM	SYMBOL	MIN	MAX	UNIT	NOTE
Power Supply Voltage	Vcc	-0.5	5	V	
Signal Input Voltage	DCLK , DE R0~R5 G0~G5 B0~B5	-0.5	Vcc + 0.5	V	
Static Electricity	VESDc	-200	+200	V	(2)
	VESDm	-15K	+15K	V	
ICC Rush Current	IRUSH	--	1	A	(3)
Operation Temperature	Top	-5	60	°C	(1)
Storage Temperature	Tstg	-20	70	°C	(1)

NOTE :

1. If users use the product out off the environment operation range (temperature and humidity) , it will concern for visual quality.
2. Test Condition : IEC 61000-4-2
VESDc : Contact discharge to input connector.
VESDm : Contact discharge to module.
3. The input pulse-current measurement system as below :

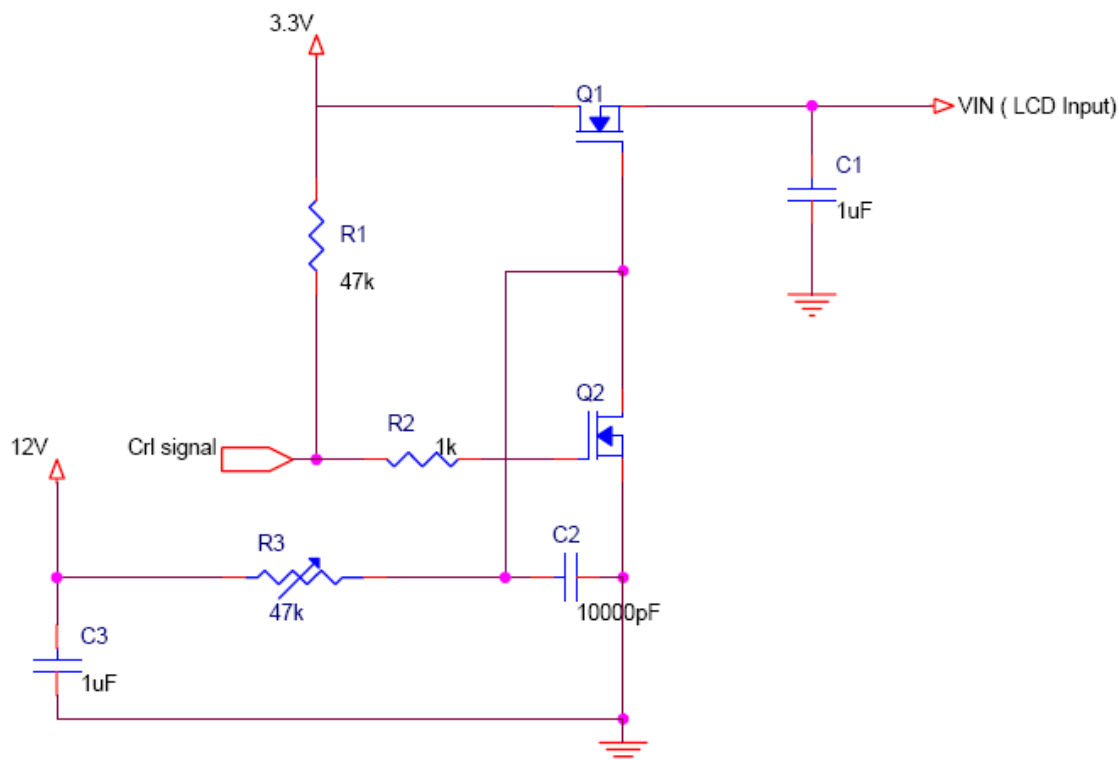

Control signal : High(+3.3V)→Low(GND)

Supply Voltage of rising time should be from R3 and C2 tune to 550 us.

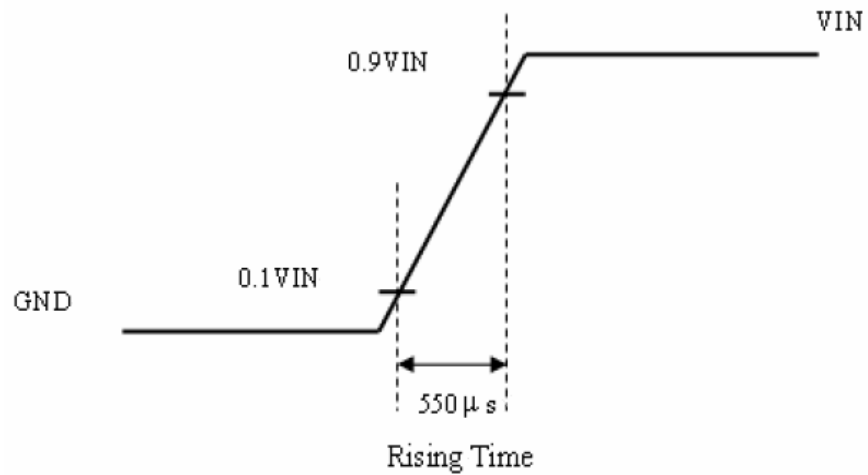

4. ELECTRICAL CHARACTERISTICS

4-1 TFT LCD Module voltage

ITEM	SYMBOL	MIN	TYP	MAX	UNIT	NOTE
Power Voltage For LCD	V_{CC}	3.0	3.3	3.6	V	(1)
Power Voltage For LED	V_{DD}	4.5	5.0	5.5	V	
Logic Input Voltage	V_{IH}	$V_{CC} \cdot 0.7$	--	V_{CC}	V	
	V_{IL}	0	--	$V_{CC} \cdot 0.3$	V	
ADJ Input Voltage	V_{IH}	3.0	--	3.3	V	
	V_{IL}	GND	--	0.3	V	

NOTE : 1. V_{CC} – dip condition :

When $2.7V \leq V_{CC} < 3.0V$, $t_d \leq 10ms$

$V_{CC} > 3.0V$, V_{CC} – dip condition should be same as V_{CC} turn-on condition

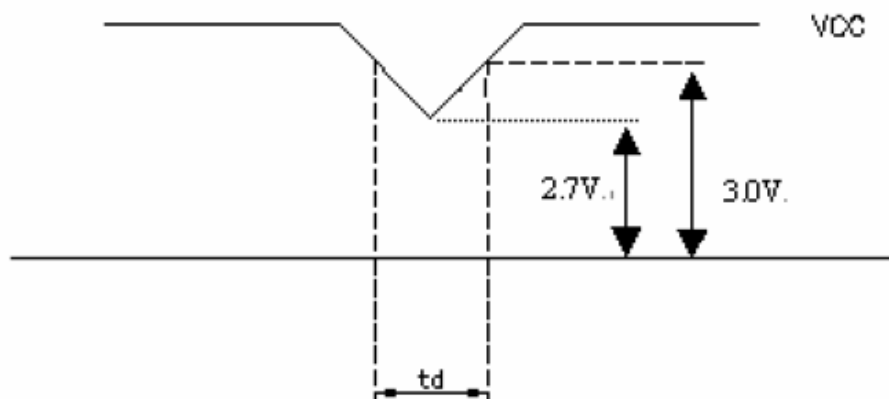

4-2 TFT LCD current consumption

ITEM	SYMBOL	MIN	TYP	MAX	UNIT	NOTE
LCD Power Current	I _{CC}	-	140	190	mA	(1)
LED Power Current	I _{LED}	-	300	350	mA	(2)

NOTE : (1) Typ : under 64 gray pattern Max : under black pattern



(a) 64 Gray Pattern

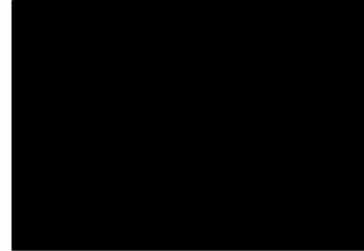

(b) Black Pattern

(2) Typ : When V_{LED} is 5.0V Max : When V_{LED} is 4.5V

One LED Dice :

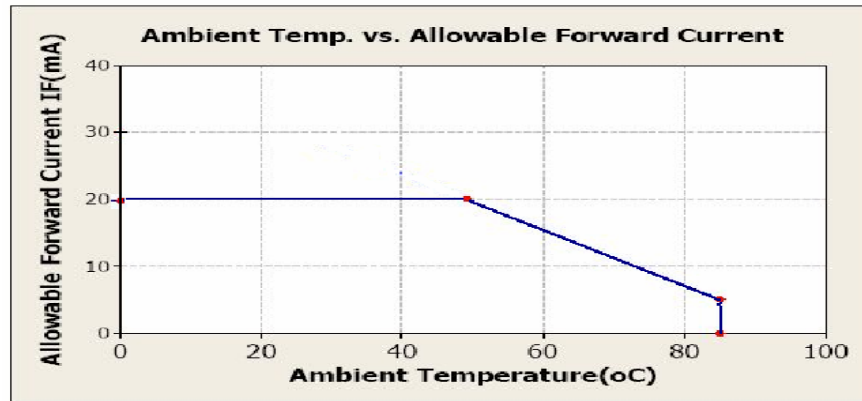

4-3 Power Signal sequence

$t1 \leq 10\text{ms}$ $50\text{ms} \leq t2$ $0 < t3 \leq 50\text{ms}$
 $0 < t4 \leq 10\text{ms}$ $1\text{sec} \leq t5$ $200\text{ms} \leq t6$
 $200\text{ms} \leq t7$

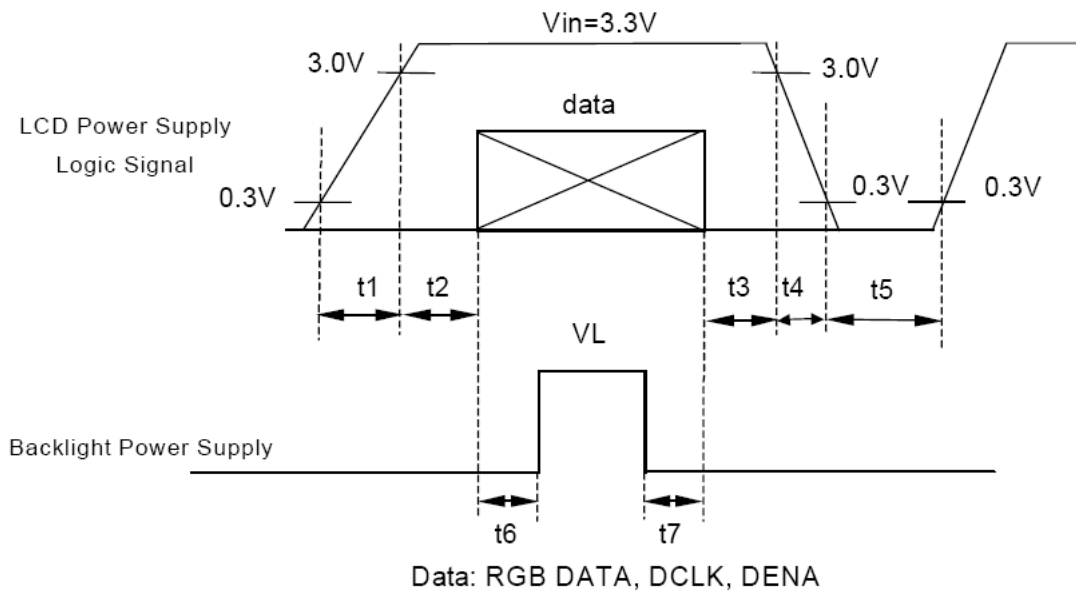

5. BLOCK DIAGRAM

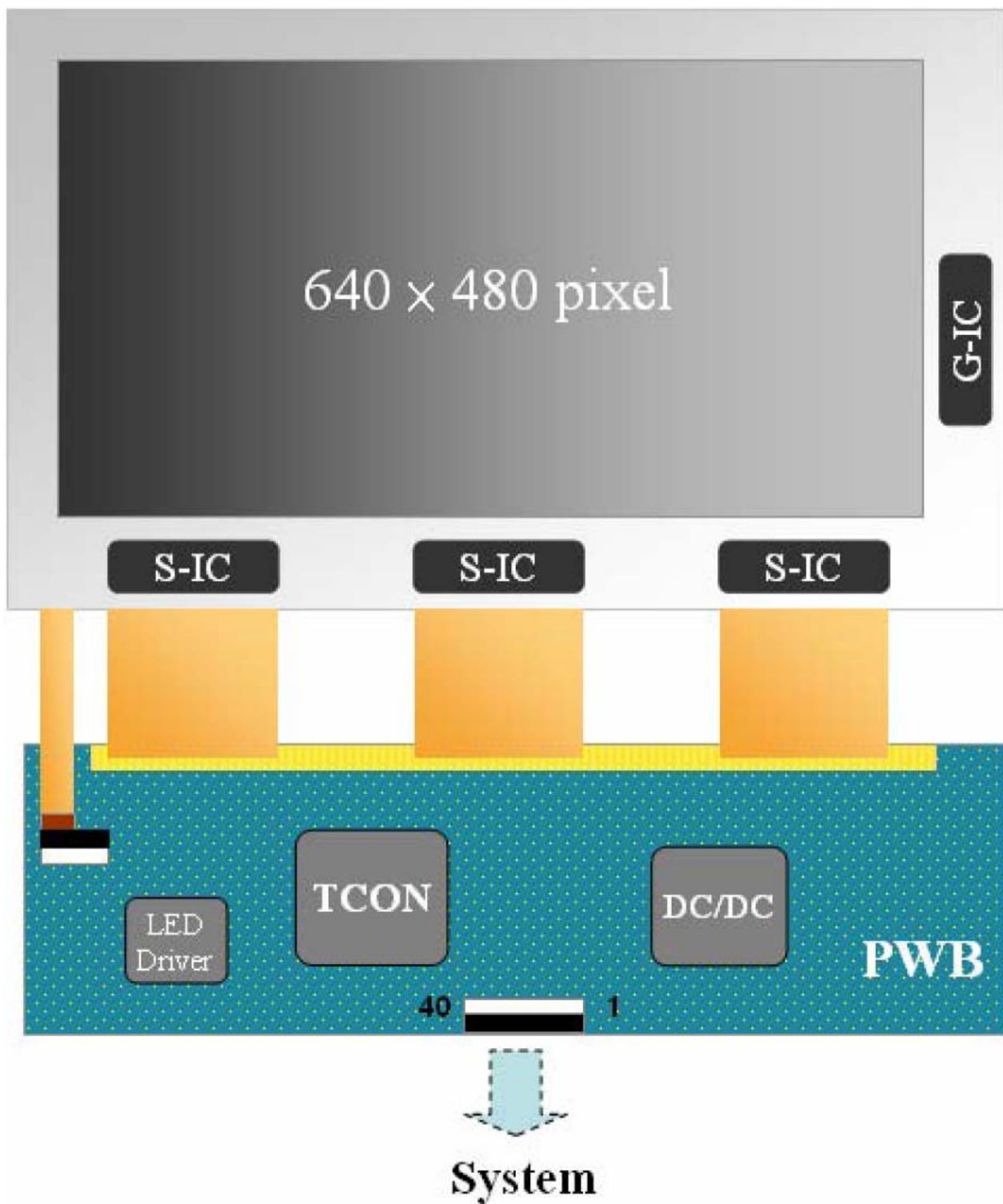

6. INTERFACE

Pin No	Symbol	Function
1	U/D	Up or Down Display Control
2	DMS	DE / SYNC Mode Selection
3	Hsync	Horizontal SYNC.
4	VLED	Power Supply for LED
5	VLED	Power Supply for LED
6	VLED	Power Supply for LED
7	Vcc	Power Supply for LCD
8	Vsync	Vertical SYNC
9	DE	Data Enable
10	Vss	Power Ground
11	Vss	Power Ground
12	ADJ	Adjust for LED Brightness
13	B5	Blue Data 5 (MSB)
14	B4	Blue Data 4
15	B3	Blue Data 3
16	Vss	Power Ground
17	B2	Blue Data 2
18	B1	Blue Data 1
19	B0	Blue Data 0 (LSB)
20	Vss	Power Ground
21	G5	Green Data 5 (MSB)
22	G4	Green Data 4
23	G3	Green Data 3
24	Vss	Power Ground
25	G2	Green Data 2
26	G1	Green Data 1
27	G0	Green Data 0 (LSB)
28	Vss	Power Ground
29	R5	Red Data 5 (MSB)
30	R4	Red Data 4
31	R3	Red Data 3
32	Vss	Power Ground
33	R2	Red Data 2
34	R1	Red Data 1
35	R0	Red Data 0 (LSB)
36	Vss	Power Ground
37	Vss	Power Ground
38	DCLK	Clock Signals
39	Vss	Power Ground
40	L/R	Left or Right Display Control

NOTE :

1. ADJ adjust brightness to control Pin , Pulse duty the bigger the brighter.

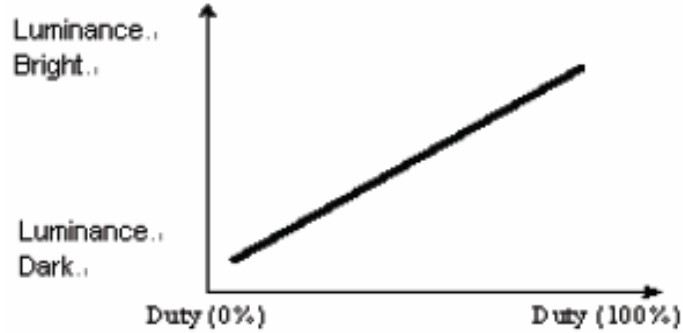

2. ADJ signal = 0 ~ 3.3V , operation frequency : $20 \pm 10\text{KHz}$

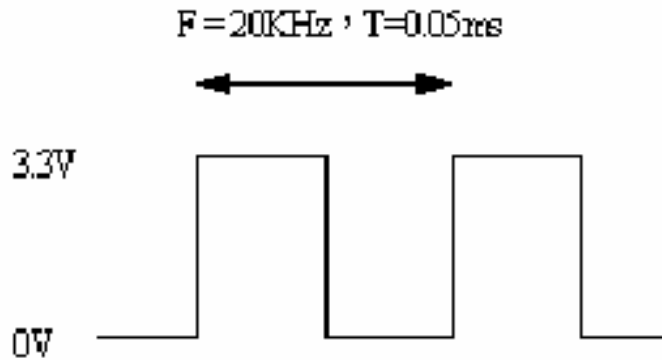

3. VSS Pin must ground contact , can not be floating.

4. U/D and L/R are controlled function

L/R	U/D	Function
1	0	Normally display
0	0	Left and Right opposite
1	1	Up and Down opposite
0	1	Left and Right opposite , Up and Down opposite

5. DMS (Selection DE / SYNC mode)

DMS	Function
1	DE Mode
0	SYNC Mode

7. INPUT SIGNAL :

7-1 Timing Specification

characteristics		Symbol	SPEC			UNIT
			Min	Typ	Max	
DE MODE	Dot Clock	F _{OSC}	23	25	30	MHz
	Horizontal Period	T _H	750	800	900	T _{OSC}
	Horizontal Valid	T _{HV}	640			
	Horizontal Blank	T _{HBK}	110	160	260	
	Vertical Period	T _{VP}	515	525	560	T _H
	Vertical Valid	T _{VV}	480			
	Vertical Blank	T _{VBK}	35	45	80	
	Vertical Frequency	F _V	55	60	65	Hz
SYNC MODE	Horizontal Period	T _H	750	800	900	T _{OSC}
	Horizontal Pulse Width	T _{HS}	1	1	1	
	Horizontal Pulse Width + Back Proch	T _{HPWB}	46	46	46	
	Horizontal Front Proch	T _{HF}	64	114	214	
	Horizontal Valid	T _{HV}	640			
	Vertical Period	T _{VP}	515	525	560	T _H
	Vertical Pulse Width	T _{VS}	1	1	1	
	Vertical Pulse Width + Back Proch	T _{VPWB}	34	34	34	
	Vertical Front Proch	T _{VF}	1	11	46	
	Vertical Valid	T _{VV}	480			
	Vertical Frequency	F _V	55	60	65	

7-2 Timing chart

Horizontal Timing Sequence

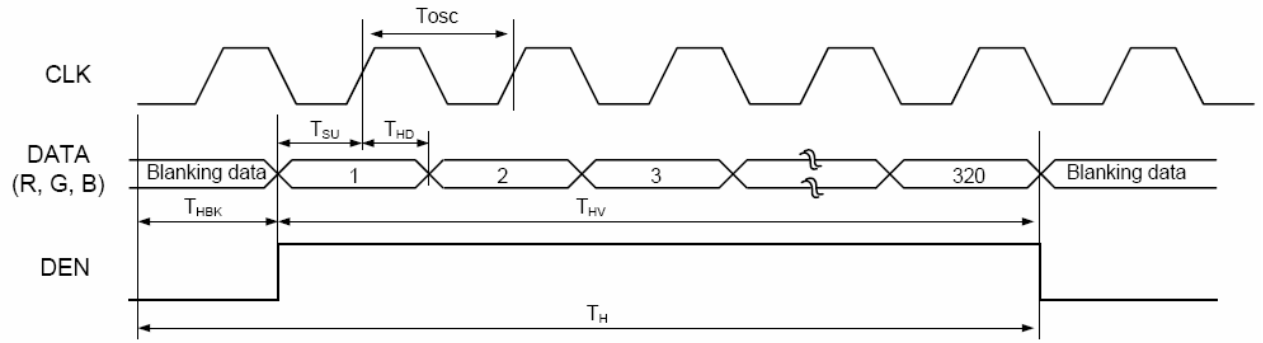

Vertical Timing Sequence

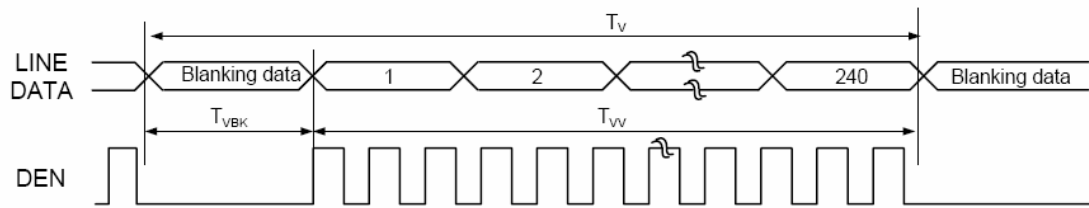

DE mode Timing

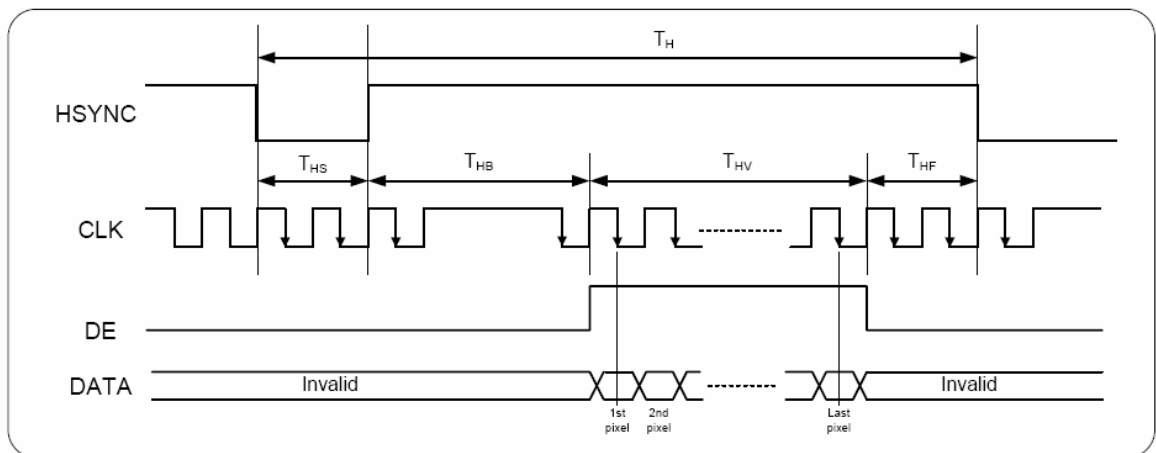
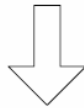
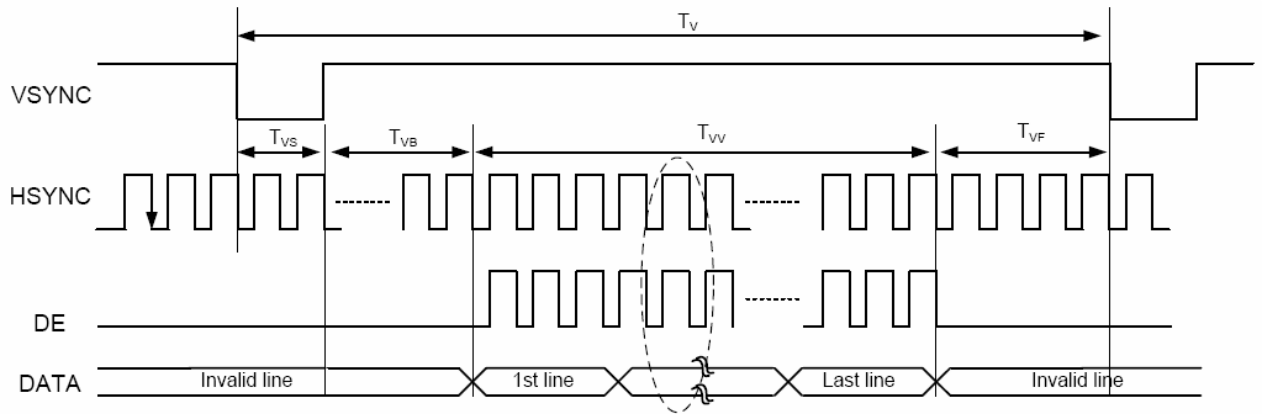

Sync mode Timing

7-3 Color Data Assignment

COLOR	Input Data	R DATA						G DATA						B DATA					
		R5 MSB	R4	R3	R2	R1	R0 LSB	G5 MSB	G4	G3	G2	G1	G0 LSB	B5 MSB	B4	B3	B2	B1	B0 LSB
BASIC COLOR	BLACK	0	0	0	0	0	0	0	0	0	0	0	0	0	0	0	0	0	0
	RED(63)	1	1	1	1	1	1	0	0	0	0	0	0	0	0	0	0	0	0
	GREEN(63)	0	0	0	0	0	0	1	1	1	1	1	1	0	0	0	0	0	0
	BLUE(63)	0	0	0	0	0	0	0	0	0	0	0	0	1	1	1	1	1	1
	CYAN	0	0	0	0	0	0	1	1	1	1	1	1	1	1	1	1	1	1
	MAGENTA	1	1	1	1	1	1	0	0	0	0	0	0	1	1	1	1	1	1
	YELLOW	1	1	1	1	1	1	1	1	1	1	1	1	0	0	0	0	0	0
	WHITE	1	1	1	1	1	1	1	1	1	1	1	1	1	1	1	1	1	1
RED	RED(0)	0	0	0	0	0	0	0	0	0	0	0	0	0	0	0	0	0	0
	RED(1)	0	0	0	0	0	1	0	0	0	0	0	0	0	0	0	0	0	0
	RED(2)	0	0	0	0	1	0	0	0	0	0	0	0	0	0	0	0	0	0
	RED(62)	1	1	1	1	1	0	0	0	0	0	0	0	0	0	0	0	0	0
	RED(63)	1	1	1	1	1	1	0	0	0	0	0	0	0	0	0	0	0	0
GREEN	GREEN (0)	0	0	0	0	0	0	0	0	0	0	0	0	0	0	0	0	0	0
	GREEN (1)	0	0	0	0	0	0	0	0	0	0	0	1	0	0	0	0	0	0
	GREEN (2)	0	0	0	0	0	0	0	0	0	0	1	0	0	0	0	0	0	0
	GREEN (62)	0	0	0	0	0	0	1	1	1	1	1	0	0	0	0	0	0	0
	GREEN (63)	0	0	0	0	0	0	1	1	1	1	1	1	0	0	0	0	0	0
BLUE	BLUE (0)	0	0	0	0	0	0	0	0	0	0	0	0	0	0	0	0	0	0
	BLUE (1)	0	0	0	0	0	0	0	0	0	0	0	0	0	0	0	0	0	1
	BLUE (2)	0	0	0	0	0	0	0	0	0	0	0	0	0	0	0	0	1	0
	BLUE (62)	0	0	0	0	0	0	0	0	0	0	0	0	0	0	0	0	0	1
	BLUE (63)	0	0	0	0	0	0	0	0	0	0	0	0	0	0	0	0	1	0

NOTE : (1) Definition of Gray Scale , Color(n) : n is series of Gray Scale
The more n value is the bright Gray Scale
(2) Data : 1-High , 0-Low

8. TOUCH PANEL ELECTRICAL SPECIFICATION

8.1 Touch Screen Panel Characteristics

1. Operation Temperature : $-5^{\circ}\text{C} \sim +60^{\circ}\text{C}$
Storage Temperature : $-20^{\circ}\text{C} \sim +70^{\circ}\text{C}$
2. Life Time : > 1,000,000 times
3. Linearity : $\leq 1.5\%$
4. TOP ITO Film : Anti-Glare Hard Coating & Anti-Newton Ring
Sheet Resistance : $380\Omega \sim 1180\Omega$;
BOTTOM GLASS : Sheet Resistance : $180\Omega \sim 470\Omega$
5. Tai Type : FPC Gold-plated
6. Meet for ROHS.
7. All Tolerance Without Marked : ± 0.3
8. Insulating Resistance : More than $20\text{M}\Omega$ at DC 25 V

8.2 Touch Screen Pane & Interface

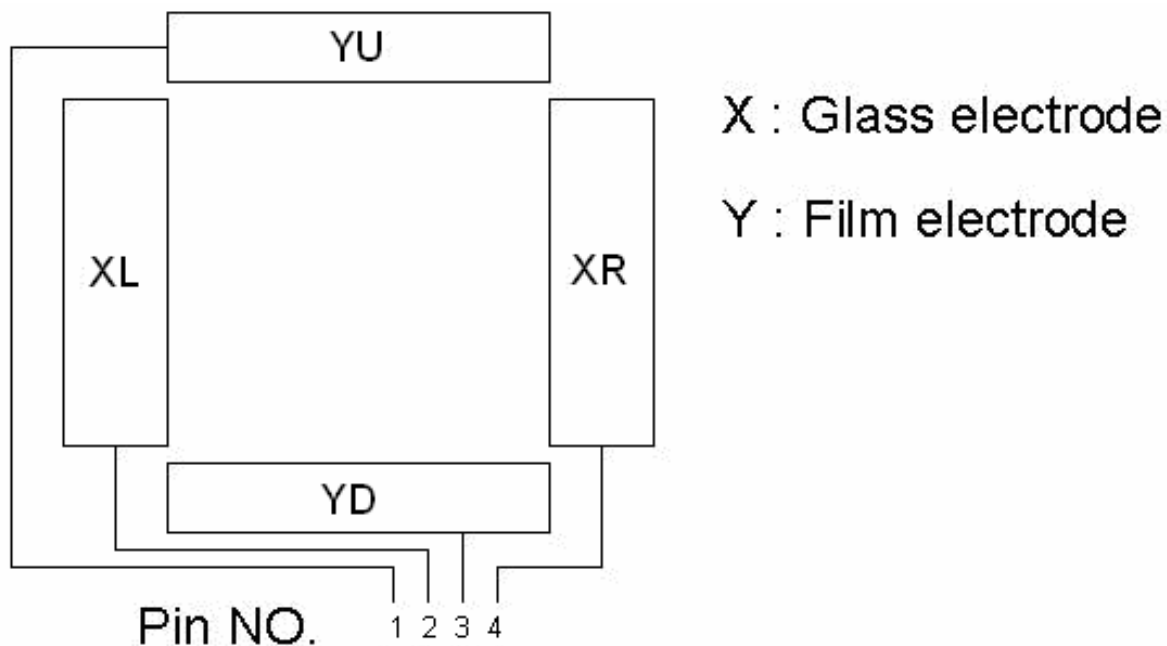

Pin No.	Symbol	I/O	Function
1	YU	Top	Top electrode – differential analog
2	XL	Left	Left electrode – differential analog
3	YD	Bottom	Bottom electrode – differential analog
4	XR	Right	Right electrode – differential analog

9. OPTICAL CHARACTERISTICS

Item	Symbol	Condition	Min.	Typ.	Max.	Unit	Note	
Contrast ratio	CR	Point - 5 $\Theta = \Phi = 0^\circ$	200	300	--	--	(1)(2)(3)	
Luminance	Lw		180	220	-	cd/m ²	(1)(3)	
Luminance Uniformity	ΔL		70	80	-	%	(1)(3)	
Response Time (White – Black)	$T_r + T_f$		--	30	50	ms	(1)(3)(5)	
Viewing Angle	Vertical	Θ	$CR \geq 10$ Point – 5	80	100	-	Deg.	(1)(2)(4)
	Horizontal	Φ		120	140	-		
Color chromaticity	Red	Rx	Point - 5 $\Theta = \Phi = 0^\circ$	0.580	0.610	0.640	--	(1)(3)
		Ry		0.306	0.336	0.366		
	Green	Gx		0.300	0.330	0.360		
		Gy		0.544	0.574	0.604		
	Blue	Bx		0.116	0.148	0.176		
		By		0.080	0.110	0.140		
	White	Wx		0.283	0.313	0.343		
		Wy		0.299	0.329	0.359		

NOTE :

- (1) Measure conditions : $25^\circ\text{C} \pm 2^\circ\text{C}$, $60 \pm 10\% \text{RH}$ under 10Lux , in the dark room by BM-5A(TOPCON) ,viewing 2° , $VCC=3.3\text{V}$, $VDD=3.3\text{V}$

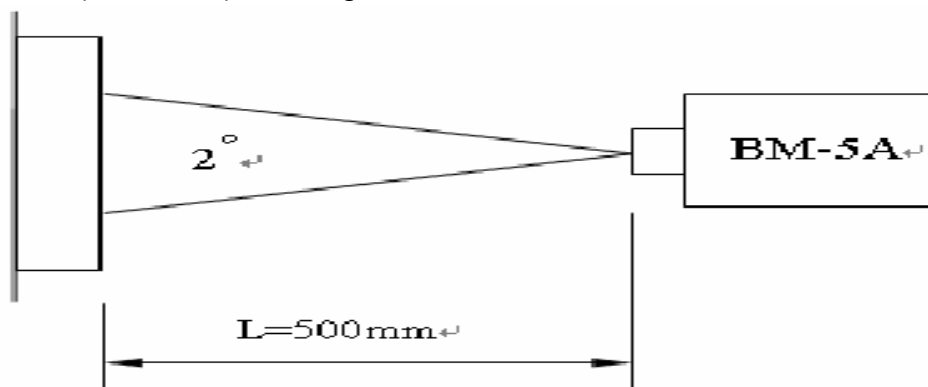

- (2) Definition of Contrast Ratio :

$$\text{Contrast Ratio (CR)} = (\text{White}) \text{ Luminance of ON} \div (\text{Black}) \text{ Luminance of OFF}$$

- (3) Definition of Luminance :

Definition of Luminance Uniformity

Measure white luminance on the point 5 as figure9-1

Measure white luminance on the point 1 ~ 9 as figure9-1

$$\Delta L = [L(\text{MIN}) / L(\text{MAX})] \times 100\%$$

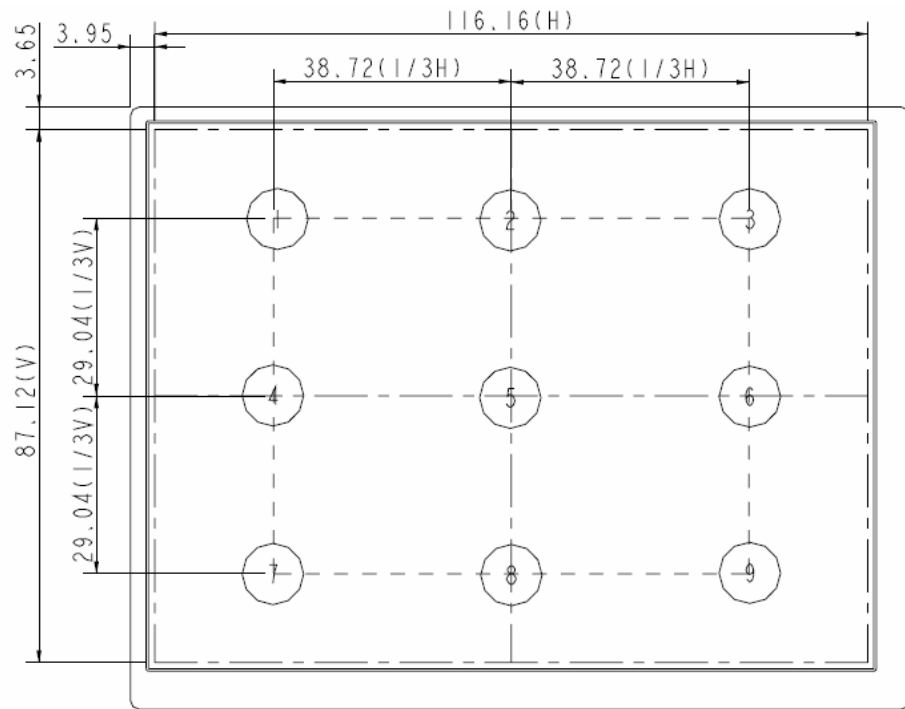

Fig9-1 Measuring point

(4) Definition of Viewing Angle(Θ, Φ), refer to Fig9-2 as below :

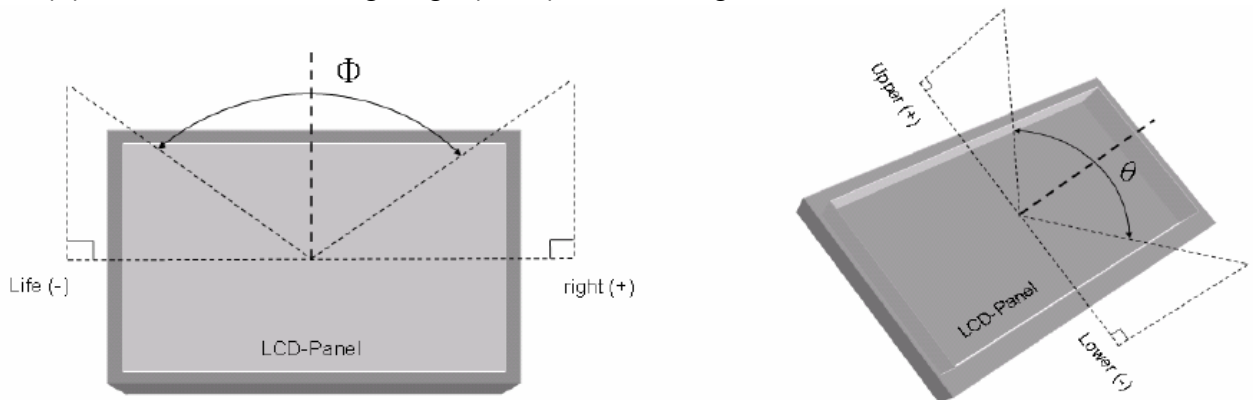

Fig9-2 Definition of Viewing Angle

(5) Definition of Response Time.(White – Black)

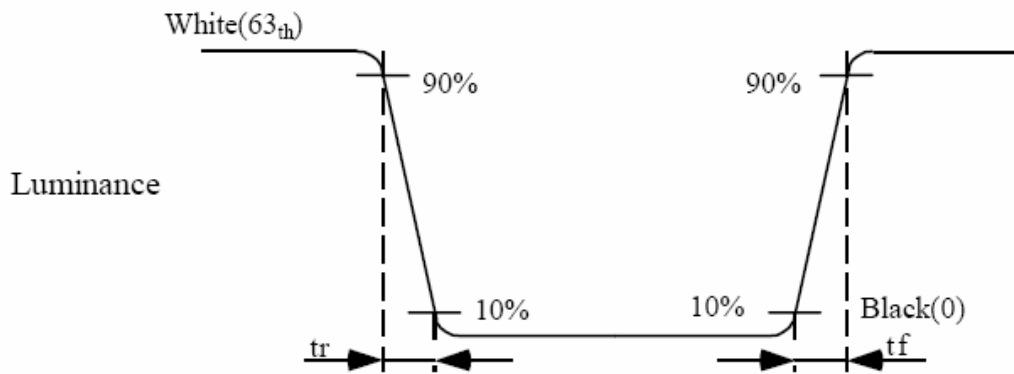

Fig9-3 Definition of Response Time(White-Black)

10. RELIABILITY TEST CONDITIONS

ITEM	CONDITIONS
HIGH TEMPERATURE OPERATION	60°C , 240Hrs
HIGH TEMPERATURE AND HIGH HUMIDITY OPERATION	60°C , 90%RH , 240Hrs
HIGH TEMPERATURE STORAGE	70°C , 240Hrs
LOW TEMPERATURE OPERATION	-5°C , 240Hrs
LOW TEMPERATURE STORAGE	-20°C , 240Hrs
THERMAL SHOCK	-5°C(0.5Hr) ~60°C(0.5Hr) 200Cycle
SHOCK (NON-OPERATIONS)	<ul style="list-style-type: none"> ● Shock level : 980m/s²(equal to 100G) ● Waveform : half sinusoidal wave, 6ms. ● Number of shocks : one shock input in each direction of three mutually perpendicular axes for a total of three shock inputs.
VIBRATION (NON-OPERATIONS)	<ul style="list-style-type: none"> ● Frequency range:8~33.3Hz ● Stoke:1.3mm ● Vibration sinusoidal wave, perpendicular axis (both x, y, z axis:2Hrs) ● sweep:2.9G , 33.3~400Hz ● cycle : 15min

NOTE : Judgment standard

The Judgment of the above test should be made as follow :

Pass : Normal display image with no obvious non-uniformity and no line defect . Partial transformation of the module parts should be ignored.

Fail : No display image , obvious non-uniformity or line defect

11. OUTLINE DIMENSION

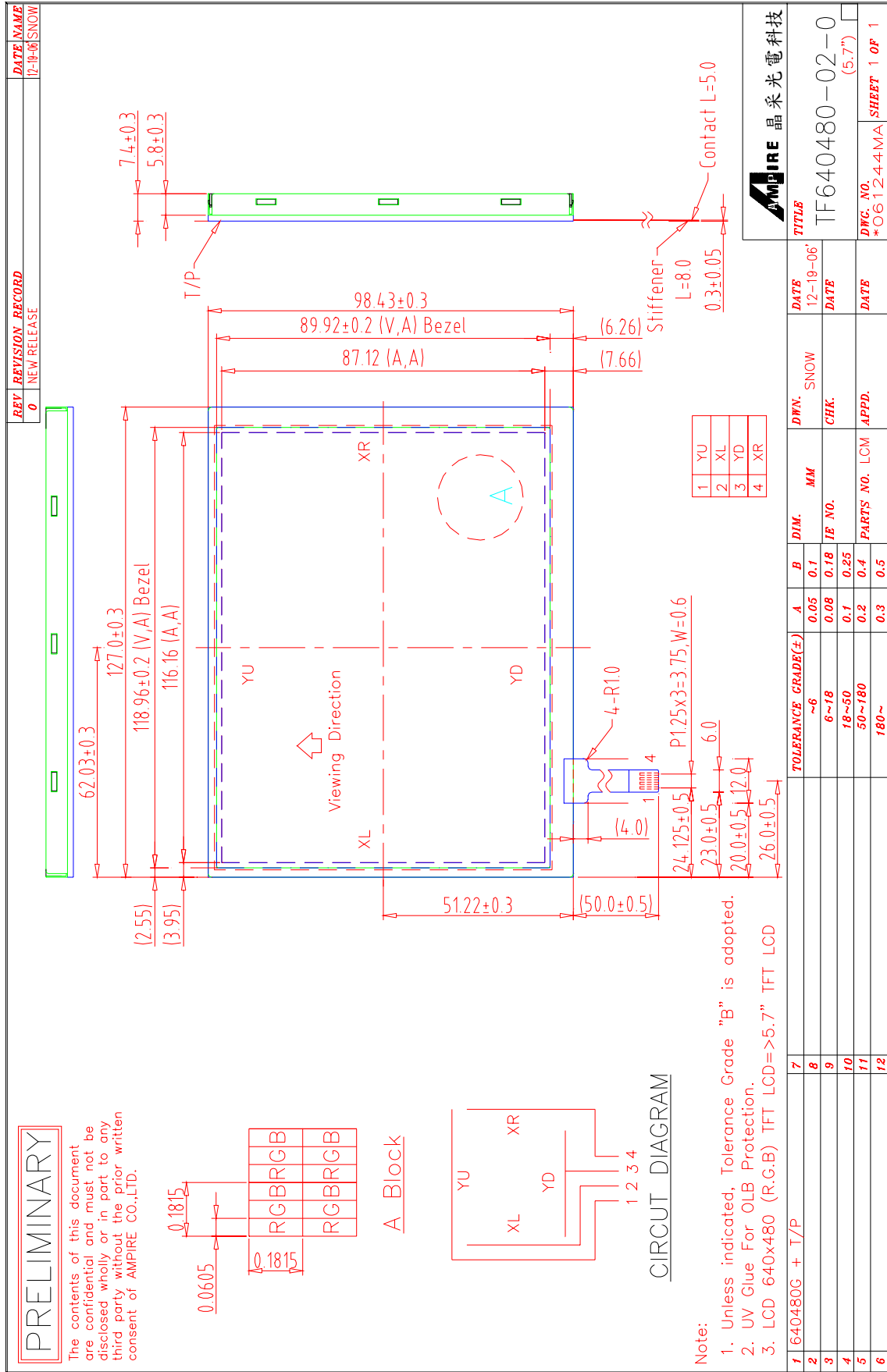

PRELIMINARY

The contents of this document are confidential and must not be disclosed wholly or in part to any third party without the prior written consent of AMPIRE CO.,LTD.

REV	REVISION RECORD	DATE	NAME
0	NEW RELEASE	12-19-06	SNOW

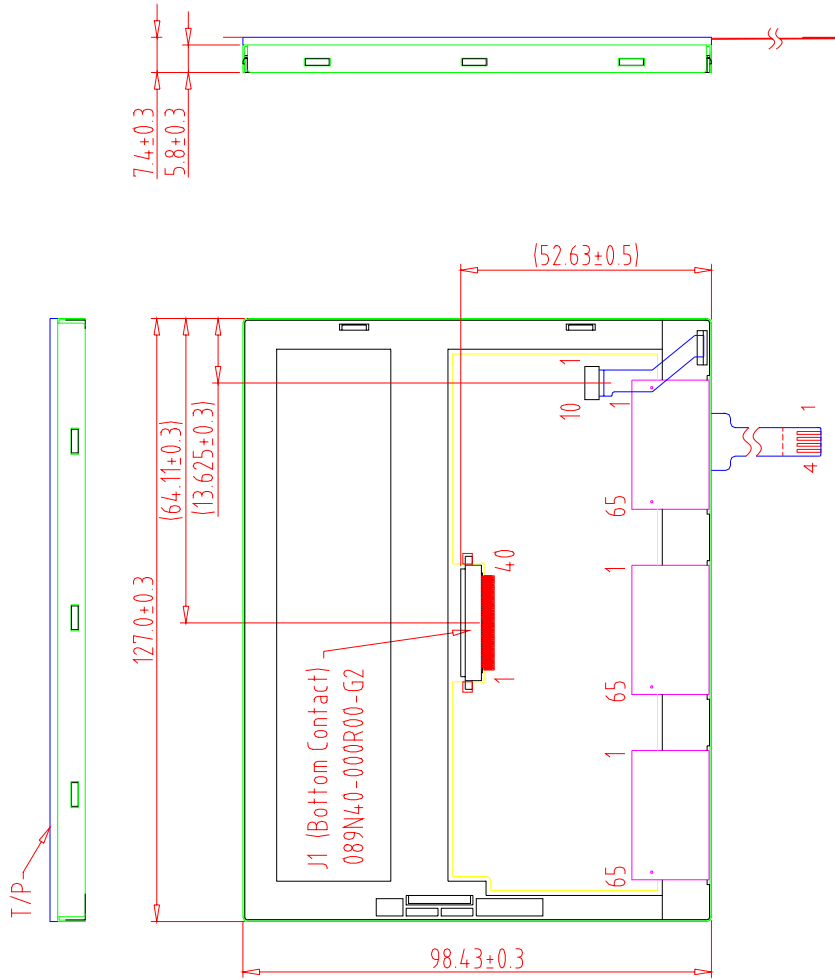

J1	
1	U/D
2	DMS
3	HSYNC
4	VCC
5	VCC
6	VCC
7	VCC
8	VSYNC
9	DE
10	VSS
11	VSS
12	ADJ
13	B5
14	B4
15	B3
16	VSS
17	B2
18	B1
19	B0
20	VSS
21	G5
22	G4
23	G3
24	VSS
25	G2
26	G1
27	G0
28	VSS
29	R5
30	R4
31	R3
32	VSS
33	R2
34	R1
35	R0
36	VSS
37	VSS
38	DCLK
39	VSS
40	L/R

- Note:
1. Unless indicated, Tolerance Grade "B" is adopted.
 2. UV Glue For OLB Protection.
 3. Main LCD 640x480 (R.G.B) TFT LCD => 5.7" TFT LCD

NO.	640480G + T/P	7	8	9	10	11	12	TOLERANCE GRADE(±)	A	B	DIM.	MM	DWN.	SNOW	DATE	TITLE
								~6	0.05	0.1				12-19-06	TF640480-02-0	
								6~18	0.08	0.18	IE NO.		CHK.		(5.7")	
								18~50	0.1	0.25			APPD.			
								50~180	0.2	0.4	PARTS NO.	LCM-1				
								180~	0.3	0.5					*OG1245MA SHEET 1 OF 1	

